

M-Power Series

Toploading Balances (Round Pans) - 0.01 g

M-Power Series



Features

- Advanced weighing technology
- High contrast LCD display
- Bi-directional RS232 interface port
- Four digital filter settings for environmental adaptation
- Three year warranty

Applications

- Academic and Research
- Pharmaceutical Laboratories
- Waste water Laboratories
- Environmental Laboratories
- Selectable applications: Counting, Percent Weighing, Unit Toggle, Animal Weighing, Net-Total

Toploader Specifications	AZ212	AZ612
Capacity	210 g	610 g
Readability	0.01 g	0.01g
Repeatability	± 0.015 g	± 0.015 g
Linearity	± 0.02 g	± 0.02 g
Corner Load	± 0.04 g	± 0.04 g
External Calibration Weight	100 g	500 g
Recommended CalPak	WCP258AC1C	WCP251AC1C
Stabilization time (average)	2.5 seconds	
Weighing Modes	Grams, Kilograms, Pounds, Ounces, Grains, Parts per pound, Milligrams, Carats, Pennyweight, Troy ounces, Taiwanese Taels, Hong Kong Taels, Singapore Taels, Chinese Taels, Mommies, Austrian Carats, Tola, Baht, Mesghal	
Applications	Net-Total formulation, Counting, Percent weighing, Averaging, Unit Toggle	
Tare Range (subtractive)	210 g	610g
Pan Size/ Type	4.5" (116 mm) diameter pan, stainless steel	
Display Type	LCD	
Overload Protection	Yes	
Overload Indication	Displays "H"	
Underload Indication	Displays "L"	
Operating Temperature	50°F to 86°F (10°C to 30°C)	
Allowable Ambient	41°F to 104°F (5°C to 40°C)	
Operating Temperature		

Foot Notes: Performance specifications measured within optimum temperature range and proper calibration. Specifications subject to change without notice.

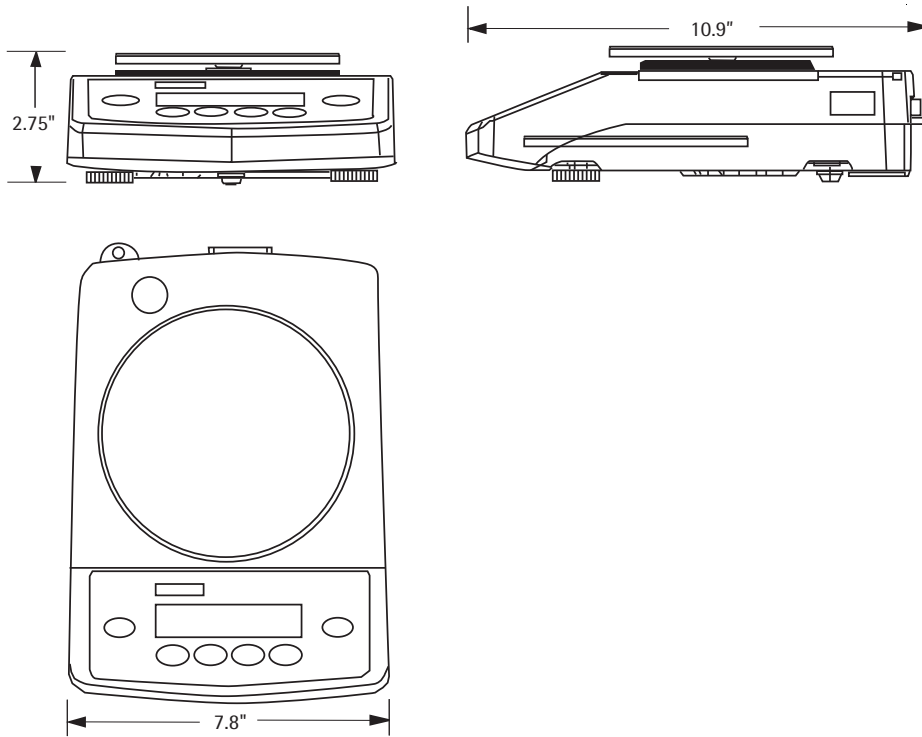

Common Specifications

Audio Tone	At start up and function keys
Adaption to Ambient Conditions	By selection of 1 of 4 optimized filter settings
Display Update	0.2-0.8 seconds (depends on the filter setting selected)
Dimensions (WxDxH)	7.8" x 10.9" x 2.75" (199 mm x 277 mm x 70 mm)
Net Weight (lbs/kg)	3.1 lbs. (1.4 kg)
Shipping Dimensions/Weight	15.3' x 11.8" x 8.6" (390 mm x 300 mm x 220 mm) / 4.9 lbs (2.2 kg)
Battery Operation	External rechargeable battery pack or 8 "AA" batteries
AC Power Requirements	AC adapter, 120V, +15%...-20%
Frequency	50/60 Hz
Power Consumption (avg)	0.75 Watt
Optional Accessories	Calibration weights, RS232 Interface Cable
Warranty	3 Year Manufacture Warranty - Parts and Labor

Foot Notes: *Performance specifications measured within optimum temperature range and proper calibration. Specifications subject to change without notice.*

Accessories	Part No.
External battery pack	YRB08Z
In-Use Cover (round pan units)	6960TE02
GLP Printer	YDP20-OCE
Power Supply 120V	6971947
Power Supply 220V	6971948
Draft Ring (5.5"/140 mm dia. - glass)	69B12180
Data Transfer Interface Cable-5 ft (fits RS232)	YCC05-001M2
RS232 (25-pin) to USB Connecting Cable	YCC0-USBM2
Remote Display, reflective 3 ft (fits RS232)	YRD02Z

Sartorius Mechatronics Canada
 7 Dunwin Drive #4
 Mississauga, ON L5L 1X2
 Phone: 905.569.7977
 Fax: 905.569.7021
 www.sartorius-mechatronics.com

Sartorius Mechatronics Corporation
 5 Orville Drive
 Bohemia, NY 11716
 Phone | 800.368.7178
 Fax | 631.253.5489
 www.sartorius-mechatronics.com

Specifications subject to change without notice.